

# Brushless DC-Servomotors

## with integrated Speed Controller

### 4 Pole Technology

7 / 13 mNm

For combination with  
Gearheads:  
22F, 22/7, 26A

## Series 2232 ... BX4 SC

|  | 2232 S                  | 012 BX4 S                 | 024 BX4 S           | 012 BX4             | 024 BX4             | SC                           |
|--|-------------------------|---------------------------|---------------------|---------------------|---------------------|------------------------------|
| 1 Nominal voltage  | $U_N$                   | 12                        | 24                  | 12                  | 24                  | Volt                         |
| 2 Terminal resistance, phase-phase                                   | R                       | 3,5                       | 12,4                | 3,5                 | 12,4                | $\Omega$                     |
| 3 Output power <sup>1)</sup>   | $P_{2 \text{ max.}}$    | 4,4                       | 4,5                 | 8,8                 | 8,9                 | W                            |
| 4 Efficiency   | $\eta \text{ max.}$     | 60,9                      | 61,7                | 66,9                | 67,6                | %                            |
| 5 No-load speed  | $n_0$                   | 13 200                    | 14 000              | 6 600               | 7 000               | rpm                          |
| 6 No-load current (with shaft $\varnothing$ 3,0 mm)                  | $I_0$                   | 0,163                     | 0,088               | 0,112               | 0,061               | A                            |
| 7 Stall torque   | $M_H$                   | 27,3                      | 29,4                | 55,7                | 59,9                | mNm                          |
| 8 Friction torque, static  | $C_0$                   | 0,6                       | 0,6                 | 0,85                | 0,85                | mNm                          |
| 9 Friction torque, dynamic   | $C_v$                   | $5,5 \cdot 10^{-5}$       | $5,5 \cdot 10^{-5}$ | $1,5 \cdot 10^{-4}$ | $1,5 \cdot 10^{-4}$ | mNm/rpm                      |
| 10 Speed constant  | $k_n$                   | 1 173                     | 616                 | 579                 | 304                 | rpm/V                        |
| 11 Back-EMF constant   | $k_E$                   | 0,852                     | 1,623               | 1,728               | 3,288               | mV/rpm                       |
| 12 Torque constant   | $k_M$                   | 8,14                      | 15,50               | 16,50               | 31,40               | mNm/A                        |
| 13 Current constant  | $k_I$                   | 0,123                     | 0,065               | 0,061               | 0,032               | A/mNm                        |
| 14 Slope of n-M curve  | $\Delta n / \Delta M$   | 504                       | 493                 | 123                 | 120                 | rpm/mNm                      |
| 15 Terminal inductance, phase-phase                                  | L                       | 130                       | 470                 | 120                 | 440                 | $\mu\text{H}$                |
| 16 Mechanical time constant  | $\tau_m$                | 22                        | 22                  | 6,7                 | 6,5                 | ms                           |
| 17 Rotor inertia   | J                       | 4,2                       | 4,2                 | 5,2                 | 5,2                 | $\text{gcm}^2$               |
| 18 Angular acceleration  | $\alpha \text{ max.}$   | 65                        | 70                  | 107                 | 115                 | $\cdot 10^3 \text{ rad/s}^2$ |
| 19 Thermal resistance  | $R_{th 1} / R_{th 2}$   | 2 / 13                    |                     | 2 / 13              |                     | K/W                          |
| 20 Thermal time constant   | $\tau_{w1} / \tau_{w2}$ | 4,1 / 274                 |                     | 4,1 / 283           |                     | s                            |
| 21 Operating temperature range                                       |                         | - 40 ... + 85             |                     | - 40 ... + 85       |                     | $^{\circ}\text{C}$           |
| 22 Shaft bearings  |                         | ball bearings, preloaded  |                     |                     |                     |                              |
| 23 Shaft load max.:  |                         |                           |                     |                     |                     |                              |
| – radial at 3 000 rpm (4 mm from mounting flange)                    |                         | 20                        |                     |                     |                     | N                            |
| – axial at 3 000 rpm   |                         | 2                         |                     |                     |                     | N                            |
| – axial at standstill  |                         | 20                        |                     |                     |                     | N                            |
| 24 Shaft play:   |                         |                           |                     |                     |                     |                              |
| – radial   | $\leq$                  | 0,015                     |                     |                     |                     | mm                           |
| – axial  | $=$                     | 0                         |                     |                     |                     | mm                           |
| 25 Housing material  |                         | stainless steel           |                     |                     |                     |                              |
| 26 Weight  |                         | 77                        |                     |                     |                     | g                            |
| 27 Direction of rotation   |                         | electronically reversible |                     |                     |                     |                              |
| 28 Number of pole pairs  |                         | 2                         |                     |                     |                     |                              |
| <b>Recommended values - mathematically independent of each other</b> |                         |                           |                     |                     |                     |                              |
| 29 Speed up to   | $n_e \text{ max.}$      | 22 500                    | 17 000              | 14 500              | 8 500               | rpm                          |
| 30 Torque up to <sup>1) 2)</sup>                                     | $M_e \text{ max.}$      | 7                         | 7                   | 13                  | 13                  | mNm                          |
| 31 Current up to <sup>1) 2)</sup>                                    | $I_e \text{ max.}$      | 0,99                      | 0,52                | 0,95                | 0,50                | A                            |

<sup>1)</sup> at 5 000 rpm

<sup>2)</sup> thermal resistance  $R_{th 2}$  not reduced

### Note:

The diagram indicates the recommended speed in relation to the available torque at the output shaft for a given ambient temperature of 22°C.

The diagram shows the motor in a completely insulated condition.

The motor is factory pre-configured to a continuous current for the thermally insulated condition. The controller must be reconfigured with the easy to use Motion Manager Software for use with other parameter settings.

The nominal voltage ( $U_N$ ) curve shows the operating point at nominal voltage in the insulated condition. Any points of operation above the curve at nominal voltage will require a higher operating voltage. Any points below the nominal voltage curve will require less voltage.

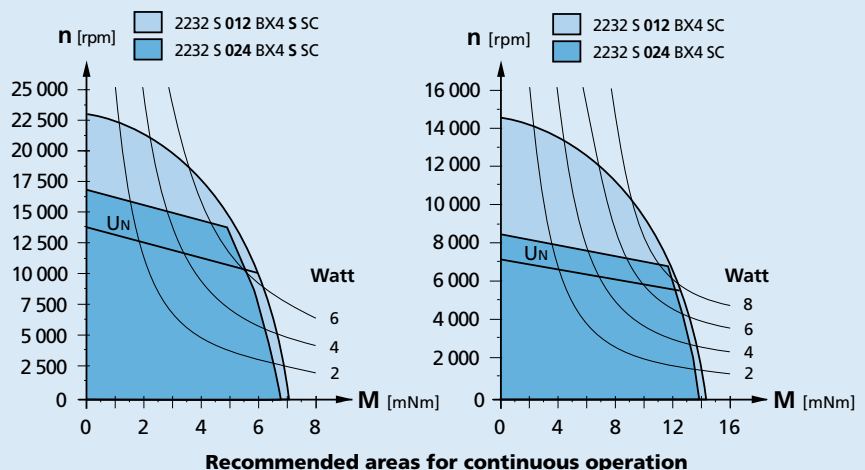

### Dimensional drawing

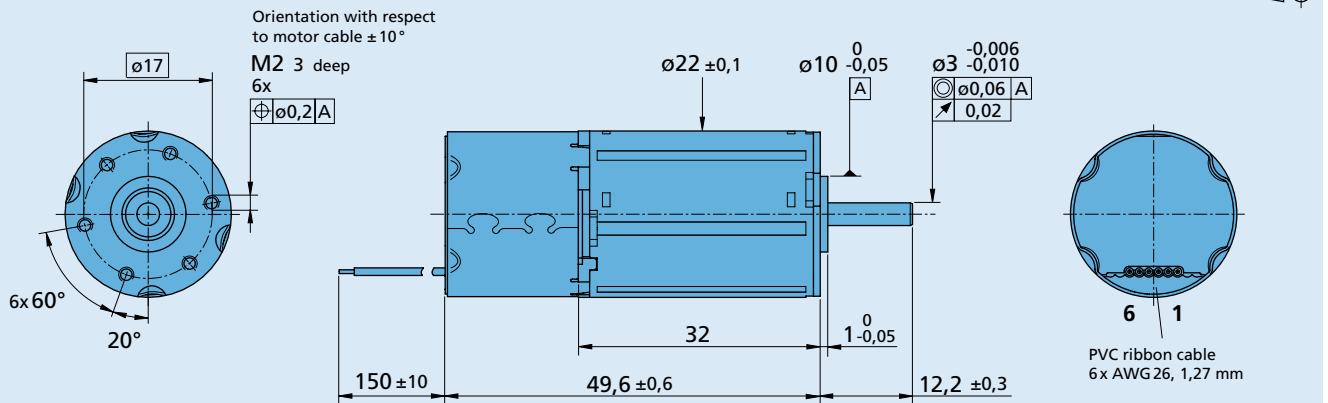

2232 S ... BX4(S) SC

| Speed Controller                             |             | 012 BX4 S                    | 024 BX4 S | 012 BX4 | 024 BX4 | SC      |
|--|-------------|------------------------------|-----------|---------|---------|---------|
| Power supply electronic                      | $U_p$       | 5 ... 28                     |           |         |         | V DC    |
| Power supply motor                           | $U_{mot}$   | 6 ... 28                     |           |         |         | V DC    |
| PWM switching frequency                      | $f_{PWM}$   | 96                           |           |         |         | kHz     |
| Efficiency                                   | $\eta$      | 95                           |           |         |         | %       |
| Max. continuous output current <sup>1)</sup> | $I_{dauer}$ | 1                            | 0,5       | 1       | 0,5     | A       |
| Max. peak output current                     | $I_{max}$   | 2                            | 1         | 2       | 1       | A       |
| Total standby current                        | $I_{el}$    | 0,020                        |           |         |         | A       |
| Speed range electronic                       |             | 400 ... 50 000 <sup>2)</sup> |           |         |         | rpm     |
| Scanning range                               |             | 500                          |           |         |         | $\mu$ s |

<sup>1)</sup> at 22°C ambient temperature and max. 60°C motor temperature respectively

<sup>2)</sup> speed depend on motor operating voltage

| Connection information              |                              | 012 BX4 S   | 024 BX4 S | 012 BX4 | 024 BX4 | SC        |
|-------------------------------------|------------------------------|---|-----------|---------|---------|-----------|
| Connection 1 "U <sub>P</sub> ":     | power supply electronic      | $U_p$   |           |         |         |           |
| Connection 2 "U <sub>mot</sub> ":   | power supply electronic coil | $U_{mot}$   |           |         |         |           |
| Connection 3 "GND":                 | ground                       | ground  |           |         |         |           |
| Connection 4 "U <sub>nsoll</sub> ": |                              |   |           |         |         |           |
| - analog input                      | input voltage                | $U_{in} = 0 \dots 10V \mid > 10V \dots U_p \gg$ set speed value not defined       |           |         |         |           |
|                                     | input resistance             | $R_{in} \geq 5k\Omega$  |           |         |         |           |
|                                     | set speed value              | per 1V  | 2 000     | 2 000   | 1 000   | 1 000 rpm |
|                                     |                              | $U_{in} < 0,15V \gg$ motor stops  |           |         |         |           |
|                                     |                              | $U_{in} > 0,3V \gg$ motor starts  |           |         |         |           |
| Connection 5 "DIR":                 |                              |   |           |         |         |           |
| - analog input                      | direction of rotation        | to ground or level < 0,5V » counterclockwise                                      |           |         |         |           |
|                                     |                              | open or level > 3V » clockwise  |           |         |         |           |
|                                     | input resistance             | $R_{in} \geq 10k\Omega$   |           |         |         |           |
| Connection 6 "FG":                  |                              |   |           |         |         |           |
| - digital output                    | frequency output             | max. $U_p$ ; $I_{max} = 15$ mA; open collector with 22k $\Omega$ pull-up resistor |           |         |         |           |
|                                     |                              | 6 lines per revolution  |           |         |         |           |

### Features

In this variant, the brushless DC servomotors have an integrated Speed Controller. The motor is commutated using Hall sensors integrated into the motor. Speed control is via a PI regulator. The Speed Controller has a current limiting device which limits the maximum motor current if the thermal load is too high. Twice the continuous current is possible over a short time.

Using the "FAULHABER Motion Manager" software, the customer can modify the Speed Controller to special conditions of use.

The following parameters can be changed: current limit and regulator parameters.

### Full product description

■ Examples:

2232S024BX4 SC

2232S012BX4S SC

**Circuit diagram / Connection information**

**Output circuit**

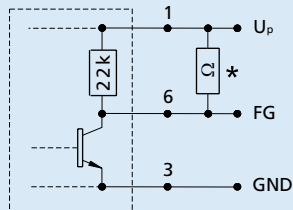

\* An additional external pull-up resistor can be added to improve the rise time.  
 Caution: I<sub>OUT</sub> max. 15 mA must not be exceeded!

**Options**

■ Connector variant (Option no.: 3809)  
 AWG 26 / PVC ribbon cable  
 with connector Micro-Fit  
 connector pin assignment:



**Cable connection**

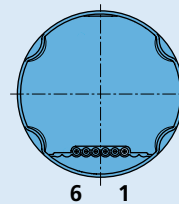

**Connection**

| No. | Function         |
|-----|------------------|
| 1   | U <sub>p</sub>   |
| 2   | U <sub>mot</sub> |
| 3   | GND              |
| 4   | Unsoil           |
| 5   | DIR              |
| 6   | FG               |

**Caution:**  
 Incorrect lead connection will damage the motor electronics!