

# DC-Micromotors

## Graphite Commutation

# 11 mNm

For combination with  
Gearheads:  
22/7, 22F, 23/1, 26A  
Encoders:  
IE3-1024, IE3-1024 L

### Series 2237 ... CXR

	2237 S	006 CXR	012 CXR	018 CXR	024 CXR	036 CXR	048 CXR	
1 Nominal voltage	$U_N$	6	12	18	24	36	48	V
2 Terminal resistance	R	0,85	3,92	8,5	15,7	33	62,8	$\Omega$
3 Output power	$P_{2 \max}$	8,6	8,1	8,7	8,5	9,2	8,6	W
4 Efficiency, max.	$\eta_{\max}$	68,1	70,8	72,2	72,6	73,6	73,5	%
5 No-load speed	$n_0$	6 900	6 800	7 000	6 900	7 200	7 000	rpm
6 No-load current (with shaft $\varnothing$ 3 mm)	$I_0$	0,124	0,058	0,039	0,029	0,02	0,015	A
7 Stall torque	$M_H$	47,2	45,7	47,1	46,6	48,7	47,1	mNm
8 Friction torque	$M_R$	0,92	0,92	0,92	0,92	0,92	0,92	mNm
9 Speed constant	$k_n$	1 283	601	409	301	207	150	rpm/V
10 Back-EMF constant	$k_E$	0,78	1,66	2,44	3,33	4,83	6,65	mV/rpm
11 Torque constant	$k_M$	7,44	15,9	23,3	31,8	46,2	63,5	mNm/A
12 Current constant	$k_i$	0,134	0,063	0,043	0,032	0,022	0,016	A/mNm
13 Slope of n-M curve	$\Delta n / \Delta M$	146	148	149	149	148	149	rpm/mNm
14 Rotor inductance	L	35	150	320	590	1 240	2 340	$\mu$ H
15 Mechanical time constant	$\tau_m$	5	5	5	5	5	5	ms
16 Rotor inertia	J	3,1	3,1	3,1	3,1	3,1	3,1	gcm <sup>2</sup>
17 Angular acceleration	$\alpha_{\max}$	152	147	152	150	157	152	$\cdot 10^3 \text{rad/s}^2$
18 Thermal resistance	$R_{th 1} / R_{th 2}$	8 / 17						K/W
19 Thermal time constant	$\tau_{w1} / \tau_{w2}$	13 / 500						s
20 Operating temperature range:								
– motor		-30 ... +100						°C
– rotor, max. permissible		+125						°C
21 Shaft bearings		sintered bearings		ball bearings, preloaded				
22 Shaft load max.:		(standard)		(optional version)				
– with shaft diameter		3		3				mm
– radial at 3 000 rpm (3 mm from bearing)		2,5		15				N
– axial at 3 000 rpm		0,3		2				N
– axial at standstill		20		20				N
23 Shaft play								
– radial	$\leq$	0,03		0,015				mm
– axial	$\leq$	0,15		0				mm
24 Housing material		steel, zinc galvanized and passivated						
25 Weight		68						g
26 Direction of rotation		clockwise, viewed from the front face						
<b>Recommended values - mathematically independent of each other</b>								
27 Speed up to	$n_{e \max}$	7 000	7 000	7 000	7 000	7 000	7 000	rpm
28 Torque up to	$M_{e \max}$	10	10,5	10,5	10,5	11	11	mNm
29 Current up to (thermal limits)	$I_{e \max}$	1,65	0,8	0,55	0,41	0,28	0,2	A

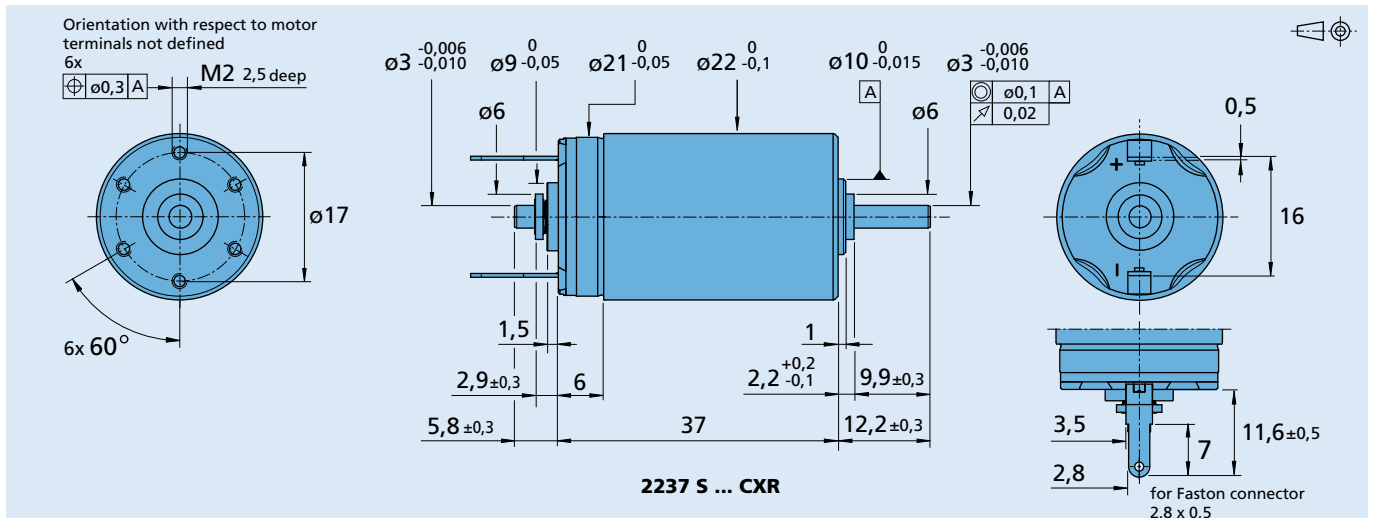

**Note:**

The left portion of the diagram indicates the recommended area of motor operation for continuous duty in a thermally insulated condition (not mounted) at room temperature 22°C.

The right portion of the diagram indicates the possible area of operation if the motor is cooled (ex.  $R_{th2} -55\%$ ) by mounting or ambient air flow conditions.

The diagram indicates the area of continuous operation for maximum lifetime performance of the motor. The motor can be driven intermittently outside of the recommended area of operation. Please consult your local product representative for more information.

The nominal voltage curve ( $U_n$ ) shows the operating points at nominal voltage. Any points of operation above the curve will require a higher operating voltage, points below will require less voltage.

